

SPDT/SP4T TTL Drivers 10 to 3000 MHz



TOSW



ZSDR

MODEL NO.	TYPE	FREQUENCY (MHz) $f_L - f_U$	INSERTION LOSS (dB)				IN-OUT ISOLATION (dB)						CASE STYLE Note B	CONNECTION	PRICE \$ Qty. (1-9)
			low-band l_w		upper band U		L		M		U				
			Typ.	Max.	Typ.	Max.	Typ.	Min.	Typ.	Min.	Typ.	Min.			
TOSW-230	SPDT	10-3000	1.3	1.9	1.8	2.7	60	40	40	28	35	22	QQ96	ee	49.95
TOSW-425	SP4T	10-2500	1.1	1.7	1.5	2.5	60	40	40	30	35	22	QQ96	ed	69.95
▲ ZSDR-230	SPDT	10-3000	1.3	1.9	1.8	2.7	60	40	40	28	35	22	CCC127	-	89.95
▲ ZSDR-425	SP4T	10-2500	1.1	1.7	1.5	2.5	60	40	40	30	35	22	GGG126	-	109.95

L = low range [f_L to $10 f_L$]

M = mid range [$10 f_L$ to $f_U/2$]

U = upper range [$f_U/2$ to f_U]

l_w = low band [f_L to $f_U/2$]

additional specifications

VSWR ("ON" STATE): 1.3 TYP., 1.9 MAX.
 SWITCHING TIME (μ SEC): 2.0 TYP., 4.0 MAX.
 SUPPLY VOLTAGE: +5V
 TTL INPUT HIGH THRESHOLD: 2 VOLTS MIN.
 TTL INPUT LOW THRESHOLD: 0.8 VOLTS MAX.

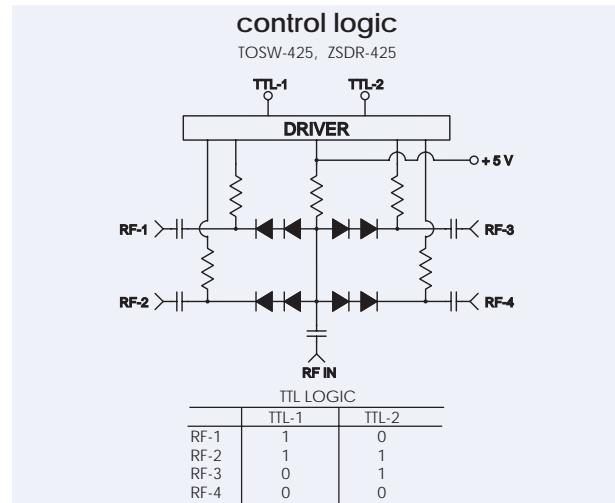
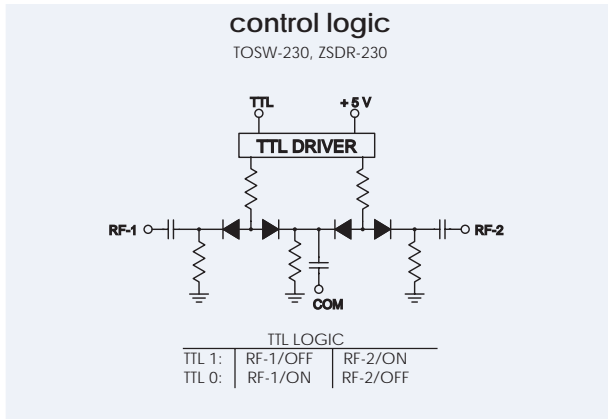

NOTES:

- ▲ Available only with SMA connectors.
 - A. General Quality Control Procedures, Environmental Specifications, Hi-Rel and MIL description are given in General Information (Section 0).
 - B. Connector types and case mounted options, case finishes are given in section 0, see "Case styles & Outline Drawings".
 - C. Prices and specifications subject to change without notice.
1. Absolute maximum RF power and control current
- | Models (all) | Power, dBm | | | Supply Current (mA) | | Control Current (mA) |
|--------------|------------|-----|-----|---------------------|---|----------------------|
| | L | M | U | | | |
| TOSW | +20 | +28 | +30 | 10 | — | — |
| ZSDR | +20 | +28 | +30 | 10 | — | — |
| PSW | +20 | +20 | +20 | — | — | 5 |
| ZMSW | +20 | +20 | +20 | — | — | 5 |

2. 1 dB Compression point: all models
- | Frequency, MHz | RF Power, dBm |
|----------------|------------------------|
| 10 to 100 | +6 increase to +19 dBm |
| above 100 | +19 min. |

pin and coaxial connections

see case style outline drawings

PORT	ed	ee
RF IN	8	8
RF OUT 1	4	5
RF OUT 2	6	11
RF OUT 3	10	—
RF OUT 4	12	—
TTL-1	2	3
TTL-2	3	—
+5V	1	1
-5V	—	—
GND EXT.	5,7,9,11	2,4,6,7,9,10,12
CASE GND	5,7,9,11	2,4,6,7,9,10,12

Plug-In & Coaxial

SPST/SPDT 10 to 2500 MHz

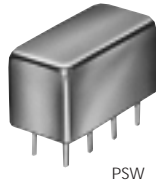

PSW



ZMSW

MODEL NO.	TYPE	FREQUENCY (MHz) $f_L - f_U$	INSERTION LOSS (dB)				IN-OUT ISOLATION (dB)						CASE STYLE	CONNECTION	PRICE \$ Qty. (1-9)
			low-band Lw		upper band U		L		frequency band M		U				
			Typ.	Max.	Typ.	Max.	Typ.	Min.	Typ.	Min.	Typ.	Min.	Note B		
PSW-1211	SPDT	10-2500	1.1	1.9	1.9	2.7	50	40	35	28	28	22	A06	ep	32.95
ZMSW-1111	SPST	10-2500	1.1	1.9	1.9	2.7	50	45	35	28	28	22	JJ77	eq	69.95
ZMSW-1211	SPDT	10-2500	1.1	1.9	1.9	2.7	50	45	35	28	28	22	JJ77	er	69.95

L = low range [f_L to $10 f_L$]

M = mid range [$10 f_L$ to $f_U/2$]

U = upper range [$f_U/2$ to f_U]

additional specifications

- VSWR 1.7 max. ("on" state)
- Switching time: 4 μ sec. max.
- Rise time: 2 μ sec typical
- Control voltage +5V on condition, 0V off condition
- 1 dB compression for all pin diode switches from 10 to 200 MHz increase from 6 to 19 dBm. Above 200 MHz, 19 dBm min.

"RF-1" Connector omitted in ZMSW-1111

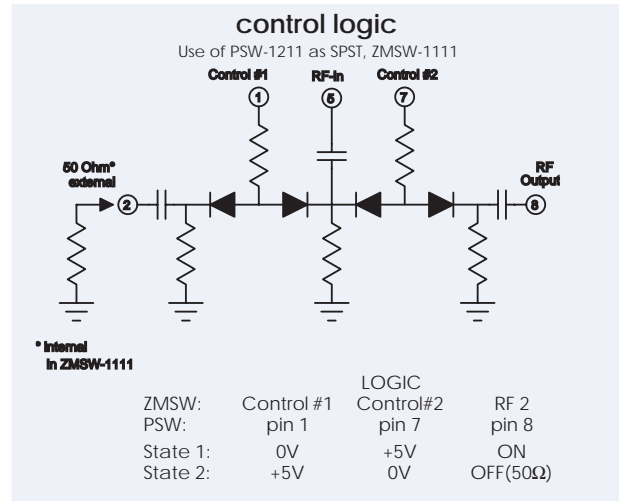
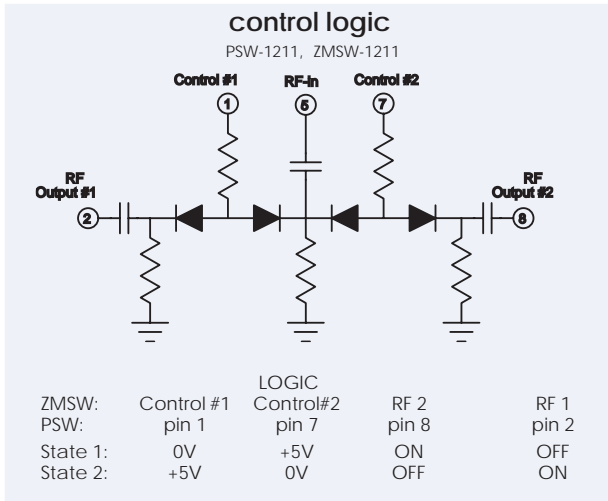

pin and coaxial connections

see case style outline drawings

PORT	ep(SPST)	ep(SPDT)	eq	er
RF IN	5	5	com	com
RF OUT 1	8	2	—	RF-1
RF OUT 2	—	8	RF-2	RF-2
CONTROL 1	1	1	1	1
CONTROL 2	7	7	2	2
50-OHM TERM.	2	—	—	—
GND EXT.	3,4,6	3,4,6	—	—
CASE GND	3,6	3,6	—	—

NSN GUIDE

MCL NO.	NSN
PSW-1211	5985-01-328-8006
TOSW-230	5985-01-456-4751
TOSW-425	5985-01-457-4811



The Design Engineers Search Engine
Provides Actual Data Instantly
At: <http://www.minicircuits.com>

In Stock... Immediate Delivery
For Custom Versions Of Standard Models
Consult Our Applications Dept.

